

SERVICE



LETTER

Service Letter No. 453

August 23, 1965

TO: Distributors, Dealers, Certified Service Centers and Owners

SUBJECT: Engine Mount Refinishing

MODELS AFFECTED: PA-24-400, Serial Nos. 26-4 to 26-69 incl., 26-71 to 26-79 incl., 26-81 to 26-96 incl., 26-98 to 26-103 incl., 26-105, 26-106, 26-108, 26-109, 26-111 to 26-125 incl., 26-128, 26-135, 26-137, 26-140, 26-147

COMPLIANCE DATE: At next 100 hr. inspection

Certain portions of the engine mount of the PA-24-400 are at the present time being finished with high temperature resistant paint.

We recommend that the engine mount and muffler supports, 24515, 24516, 24517 and 24518 be refinished according to the sketch and instructions on the reverse side of this letter.

The engine mount tubes affected are one inch (1") in diameter. The amount of metal that may be removed to completely clean the tubes prior to painting cannot exceed .0035 (3 1/2 thousandths) in any one area or reduce the total diameter of the tube by more than .007 (7 thousandths) on the horizontal tubes. Metal removed from the vertical tubes cannot exceed more than .0065 (6 1/2 thousandths) in any one area or reduce the total diameter by more than .013 (13 thousandths).

This paint, which will be known as Therm-Pac, will be available in 12 ounce spray cans under Piper part number 756 306.

One can of paint will be supplied for each PA-24-400 according to serial numbers listed above. The serial number of the aircraft must be listed on the purchase order.

NOTE

The above listed material will be available for general use on all models, where a high temperature resistant finish is desired, at a suggested retail price of \$1.80% per can.

650818

PIPER AIRCRAFT CORPORATION. LOCK HAVEN, PA., U. S. A.

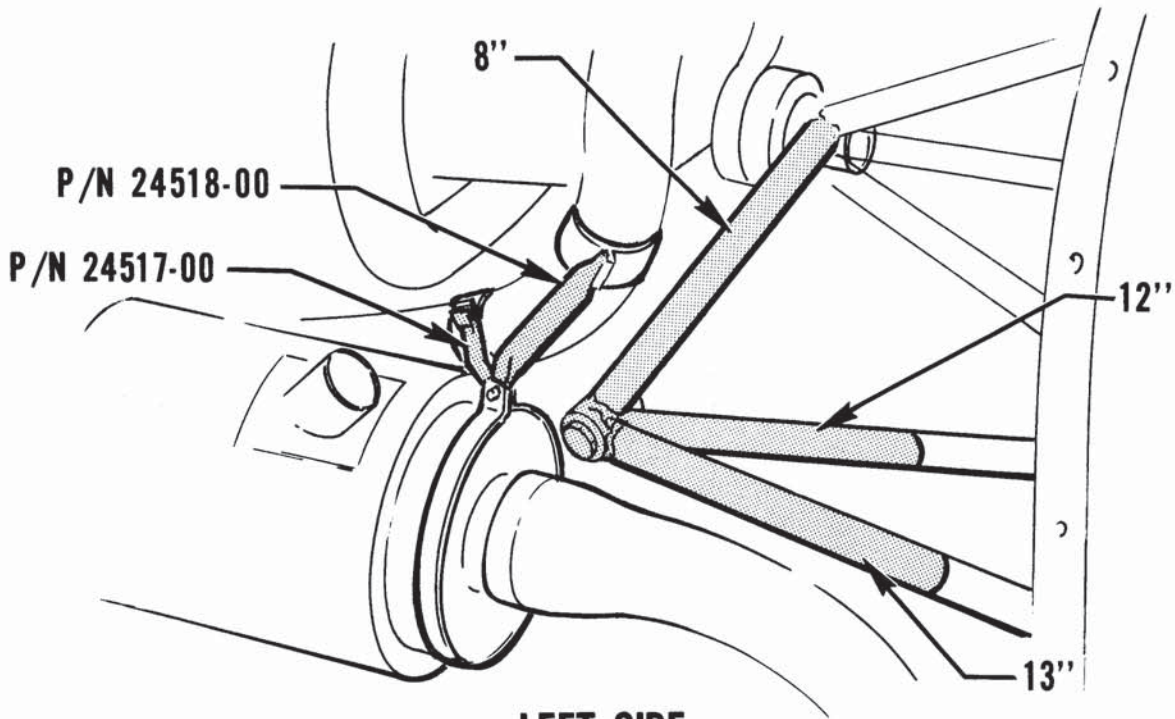

LEFT SIDE

NOTE:

**PAINT SHADED AREA
TO DIMENSIONS SHOWN**

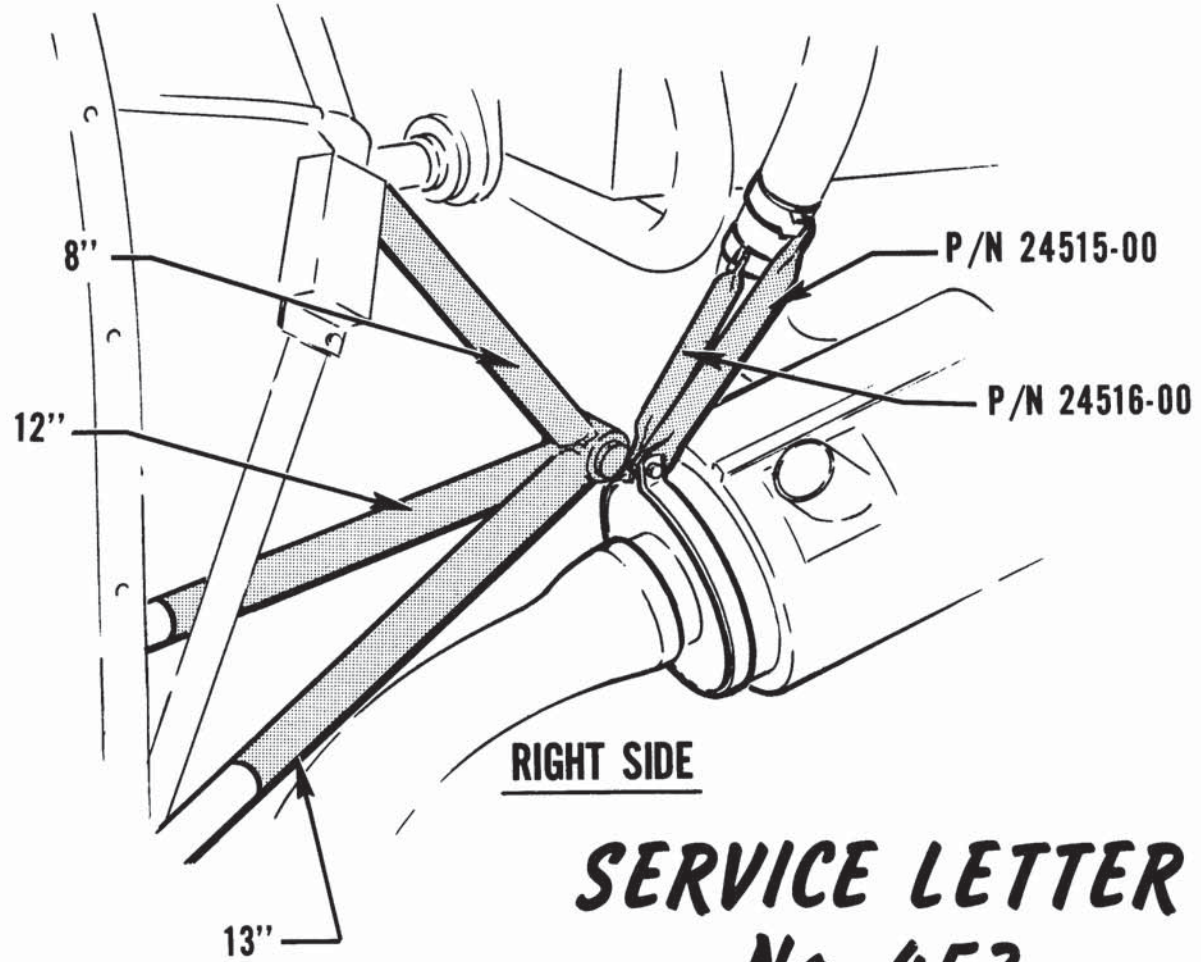

RIGHT SIDE

***SERVICE LETTER
No. 453***